

SLIDEKAMERA



NEXT LEVEL OF FILMMAKING



BULL™ HEAD

REMOTE CONTROLLED HEAD

User Manual

pdf version of the manual available for download: www.slidekamera.com



9/2016

Before you start your work with Slidekamera BULL HEAD remote controlled head we strongly recommend to read the manual carefully.

Please note that using the head in a manner inconsistent with the manual can cause damage or malfunction the manufacturer is not responsible for.

Table of contents

1. Technical specification.....	2
2. Elements of the head.....	3
3. Construction	3
4. Power supply.....	4
5. Mounting.....	4
6. Connections.....	5
7. AION 2D controller.....	6
8. Working with BULL HEAD and AION 2D	6
9. Calibration	8
10. Maintenance and operation.....	8
11. Terms of warranty	8

Slidekamera®
High Engineering Technology CNC s.c.
Sebastian Pawelec Karol Mikulski
Glińska 45
82-522 Sadlinki
VAT Identification Number: 581-188-33-32

Slidekamera Office
80-175 Gdańsk (Poland)
ul. Kartuska 386
tel./fax (+48) 58 710 41 04
e-mail: biuro@slidekamera.com
www.slidekamera.com

1. Technical specification

Weight:	5kg
Head dimensions:	300mm x 330mm x 110mm
Head load capacity:	8kg
Maximum size of the camera:	width: 175mm height: 270mm
Range of head rotation angles:	N x 360° (in the X-axis and Y-axis)
Maximum rotation speed:	73°/s (360°/4.9s)
Maximum acceleration:	264°/s ²
Supply voltage:	10..17V DC min 40W
Battery working time:	12V 7Ah min. 3h
Operating temperature range:	od 0 do +40°C
Recommended relative humidity:	do 90%

2. Elements of the head

Set includes:

- [1] BULL HEAD remote controlled head
- [2] AION 2D controller
- [3] steering cable: 5 meters
- [4] 1/4" camera head screw
- [5] 3/8" camera head screw
- [6] AC adapter
- [7] transport case with foam insert
- [8] user manual



[1]



[2]



[6]



[3]

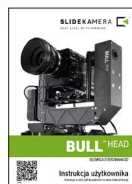

[8]

3. Construction

Thanks to the use of worm gears and steering, that maintains steady speed regardless of the load, the head does not require precise balancing. Compact and cased construction ensures long and problem-free operating.

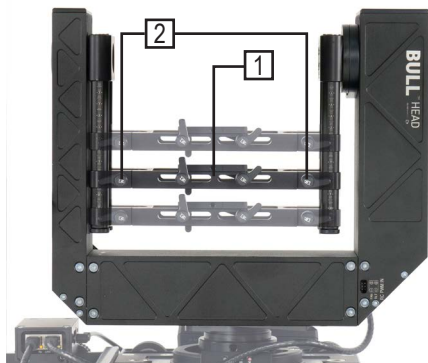

Mounting bracket [1] moves up and down, allowing to set the accessories in the rotation axis of the head.

Four adjustable clamping levers [2] facilitate rigid mounting of the mounting bracket.

Accessories are mounted on the mounting bracket with the use of 1/4" lub 3/8" screws.

BULL HEAD is equipped with a TRIGGER socket to connect our device with a photo camera using a proper shutter release cable, thus allowing for interval shots synchronized with a slow movement of the head.



- [1] IN socket - to connect controller or SLIDE LINK wireless adapter
- [2] OUT socket - control output for another Slidekamera device (connect to it's IN socket)
- [3] Power socket
- [4] TRIGGER - Shutter release cable socket

Driving motor markings:

LINK	Green light indicates, that controller cable is properly connected.
Rx	When orange light flashes slowly the user is informed, that the driving motor is powered, but is not receiving any command from the controller. When orange light starts flashing rapidly this indicates that the driving motor received a command from the controller.
FAULT	Flashing light indicates existing error.

4. Power supply

BULL HEAD can be powered by many 10-17V DC power sources (min. 40W power output), such as:

- AC power adapter (included in the set)
- external battery - Slidekamera AF-7 power pack
- battery with D-tap connector (e.g. V-lock battery)

5. Mounting

3/8" hole in the head base allows to mount it on other devices equipped with 3/8" screw, such as sliders, cranes and tripods.

PLEASE NOTE:

Do not tighten up the BULL HEAD by holding it's housing, as it may damage the motor gear!

There are holes in the base of the head, that are used to tighten up the device. Insert appropriate tool (such as screwdriver or hex key) into the hole and use it to tighten the mounting screw.

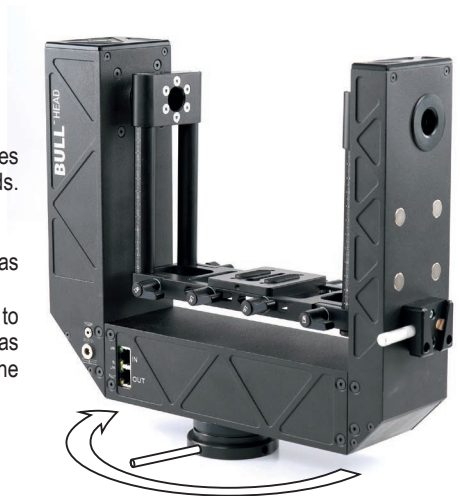

To mount the BULL HEAD faster and easier, use additional quick release plate [1], that secures the head and helps mounting the unit correctly.

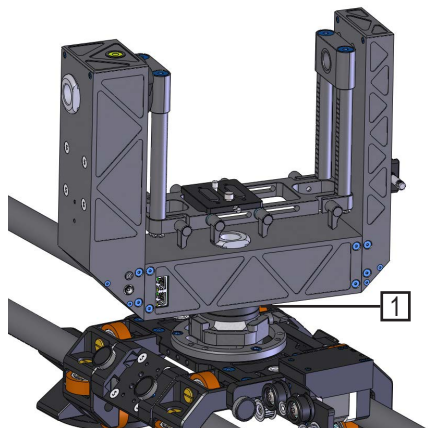

6. Connections

BULL HEAD can be controlled by a wide range of devices (AION controllers, SLIDE LINK wireless adapter, etc.) and work with other elements of the motion control system, such as slider motors. Many devices can be connected to one controller and the order of the devices is not important.

Connecting BULL HEAD to the controller and other devices:

- connect controller (e.g. AION 2D, SLIDE LINK) to the first device of your choice, to it's IN socket using steering cable
- further device (if there is any) connect by connecting it's IN socket with OUT socket of the previous device
- connect power supply to devices, that requires external power source for their motors (heads, sliders, etc.)
- controlling devices may include own batteries or be powered by steering cable

Examples of connecting BULL HEAD with other devices:

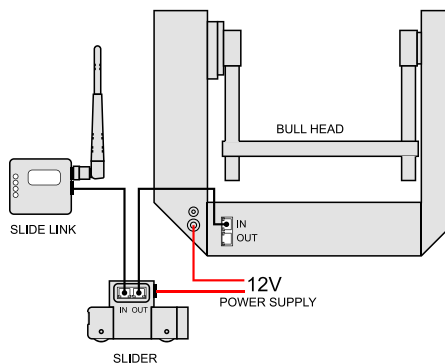
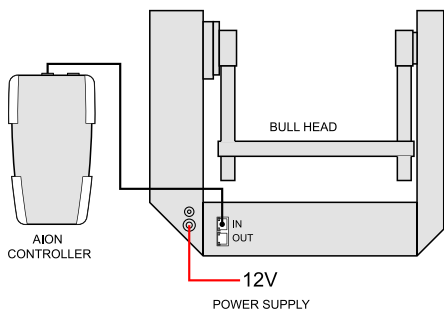

7. AION 2D controller

Joystick and the knobs are located on the front panel of the controller. Electric connectors sockets and the power switch are located on the top wall of the controller housing.

Front panel:

- [1] joystick
- [2] MEM keys
- [3] INVERT keys
- [4] DAMPING knobs
- [5] SPEED knobs

Top wall of the housing:

- [6] power switch
- [7] steering output socket



8. Working with BULL HEAD and AION 2D

The set includes AION 2D wired controller. You can control the BULL HEAD wirelessly with additional Wi-Fi adapter SLIDE LINK and mobile app on your tablet with Android or iOS operating system.

Basic functions of the AION 2D controller:

Live mode:

- accurate and intuitive control thanks to precise joystick
- smooth change of maximum speed (1-100% of the motor's top speed)
- precise control of soft start / stop (from 0.1 to 5 seconds)
- quick reverse of the movement direction of any axis (by one click)
- greater precision of control thanks to the ability to change joystick characteristics (LIN <-> LOG)
- separate disable for every axis

record / playback:

- 3 banks of non-volatile memory for motion recording and playing back
- playback always starts from the same point (exactly where the recording has begun)
- smooth control over the playback speed (by **SPEED** knob of the **X** axis)
- ability to loop playback

calibration and settings:

- easy and fast calibration (setting range of the movement) of every axis
- memory of a user settings (reverse of the movement direction of any axis, joystick characteristics) and saved trajectories

Controlling the motion

Precision and ergonomics of the controlling device is provided by analog joystick. Deflection of it's stick dynamically changes the speed of the head's rotation. There are two modes to choose: **LIN** (joystick's position translates linearly to the speed of the rotation) and **LOG** (this mode gives more precise control in low rotation's speed).

SPEED knobs allows to change the top speed of a particular axis. Turning the knob clockwise increases the speed, that corresponds to the extreme position of the joystick. Turning the knob counter-clockwise lowers the speed and eventually turns the axis off (**INVERT** key backlight will turn off).

RAMP knobs allows to change soft start and stop of a particular axis. Turning the knob clockwise will increase the time of fluid acceleration. Smooth deceleration occurs when the joystick returns to center (neutral) position.

PLEASE NOTE: If the joystick is pushed rapidly in opposite direction, the head will stop immediately (without smooth deceleration) and will start to rotate in the opposite direction.

INVERT switches allows to:

- change direction of a particular axis (by one click)
- change joystick's characteristics (**LIN**<->**LOG**) of a particular axis - by holding the key (>0.7s). Backlight color indicates chosen characteristics (**LIN** - green, **LOG** - red).

Record and playback

AION 2D controller has 3 banks of non-volatile memory (recorded motion is saved even if the controller is turned off and power supply is disconnected). In every bank there can be recorded one trajectory. Maximum duration of the recording is 200s for **MEM 1** and 100s for **MEM 2** and **MEM 3**.

Record:

To start recording, hold chosen **MEM** key (backlight of the button will start flashing). Use controller as normal. Motion will be recorded. You can use **SPEED** and **DAMPING** knobs the same way, as in Live mode. To stop recording, press **MEM** key. Recording will stop automatically when it reaches time limit.

Playback:

To play back recorded movement trajectory press corresponding **MEM** key (the backlight of the button will turn on). To stop playing back press **MEM** key once again.

During playing back you can adjust the speed of the motion with the **SPEED** knob of the **X** axis.

To enable **LOOP** mode (playing back in loop) start playback by pressing **MEM** key twice ("double-click").

Going to the start position

Playback always starts from exactly the same position, from which record has been started. The head has to reach this point before playing back recorded trajectory. During this motion **INVERT** key is flashing. By using **DAMPING** knobs before playing back, you can ease reaching the starting point and reduce unwanted vibrations. Speed and acceleration of the head's return to the start position can be controlled by **SPEED** and **DAMP** knobs.

9. Calibration

AION 2D has a calibration feature - memory of extreme positions, that will never be exceeded. This prevents breaking off cables or damaging the camera.

Each axis is calibrated separately.

To calibrate particular axis, press and hold (>5s) its **INVERT** button. Backlight of the **INVERT** button will start flashing red and green, in the same time backlight of the **MEM 1** button will start flashing.

Go to the first extreme position of the axis, that is being calibrated and press **MEM 1** to save it. Backlight of **MEM 1** button will turn off, the **MEM 3** button will start flashing. Set the head in second extreme position and press the **MEM 3** to save it. The calibration of the first axis is finished. If necessary, repeat above steps for second axis.

BULL HEAD will store calibration in it's memory, even if the power supply is disconnected. If the working conditions haven't been changed, the head is ready to work immediately after turning it on.

10. Maintenance and operation

BULL HEAD remote controlled head does not need any additional service or lubrication of the components. Maintenance procedures are reduced to keeping the equipment clean.

11. Terms of warranty

All Slidekamera products are covered by the manufacturer's warranty for a period of 12 months from the date of sale. Warranty covers production faults and material defects, which resulted in the product malfunctioning. Warranty covers the repair, or, if the repair proves impossible, replacement of the product with a new one. However, the cost of repair of the product cannot overrun the catalogue value of the product. The warranty does not cover damage and / or product defects resulting from the improper usage, as well as not following product maintenance specifications.

The warranty excludes:

- unauthorized attempts to repair or modify
- mechanical damage caused during transport and operation of such features as scratches, dents, pits, dirt, etc.
- flooding, moisture

To obtain warranty service the purchaser should deliver the damaged product together with a proof of purchase or proof of payment (invoice, cash register receipt). The product will be accepted for warranty service on condition, that it is delivered with correctly filled in complaint form and properly protected during transport. The complaint form is available for download at: www.slidekamera.com

After the warranty period is exceeded any spare parts can be purchased directly from the manufacturer or in any selected points of sale.

PLEASE NOTE:

Any package sent at the expense of HET-CNC s.c., 80-175 Gdańsk, ul. Kartuska 386 will not be received.