



YAMAHA CORPORATION
P.O.BOX1, Hamamatsu Japan

<http://www.yamahaproaudio.com/>

*All specifications are subject to change without notice.
*All trademark and registered trademarks are property of their respective owners.

DIGITAL MIXING CONSOLE
DM3
DM3/DM3 Standard

DO MORE

The word “compact” is often associated with limitations, and in the sound reinforcement world, often implies compromises in functionality, connectivity, or sound quality, and sometimes all three. Until now choosing a compact console has almost invariably been a matter of what you’re willing to sacrifice to get the capabilities you need in the space you have. The new DM3 series of mixing consoles shatters this stereotype, offering superb sound quality, fast and easy setup and operation, and professional-level features for live sound, streaming, and live or home recording and music production—a combination unmatched in any other mixing console this size. In an ever-changing world that constantly presents new challenges as well as opportunities, DM3 mixing consoles give you the power and flexibility to do more with than you ever imagined with a compact digital console.



P06 Live Sound



P08 Streaming



P10 Recording



P12 Installed sound



Line up
DM3: with Dante
DM3 Standard: without Dante



RAISING THE BAR FOR COMPACT DIGITAL MIXERS

In 1987 Yamaha released the first ever digital mixer, the DMP7, ushering in a new era of consoles that boasted greater functionality in a more compact design than their analog counterparts. Decades later the DM3 Series is setting a new standard for compact console performance, featuring versatile capabilities and extreme portability that make it an invaluable tool for a wide range of applications and environments.

The DM3 Series comprises two models, the DM3 Standard and the DM3—the first compact console to be fully compatible with Dante technology, allowing for faster and easier setup with multiple devices. Both consoles feature a multi-language user interface that can be configured to make operation simple and trouble-free for users with different backgrounds and varying skill levels.

Equally at home in a live performance venue or your home studio, it's easy to imagine taking a DM3 Series console to a gig, recording and streaming the audio, and then taking it home for editing as part of your DAW setup. Alternatively, you could use it as a main mixer for a small performance one day, and as a sub-mixer for live streaming the next—the possibilities are endless.



A legacy of sonic purity

The ideal starting point for any audio engineering endeavor is transparent, uncolored sound. All Yamaha mixers are built on that philosophy, with the goal of allowing engineers to capture the on-stage sound accurately, without coloration, and then add creative touches as required.

Capable of sampling rates as high as 96 kHz despite its compact size the DM3 Series continues this legacy of sonic purity, offering you the perfect starting point for mixing, recording, live streaming, or even installed applications.



Simple. Intuitive. Powerful.

Perhaps the most significant advantage of a digital console is the ease of operation and accessibility of powerful functions and features that would otherwise require a higher level of user experience as well as more outboard gear to actualize in an analog setup. The DM3 Series exemplifies a “less is more” design philosophy, utilizing a 9” touchscreen and a single Touch & Turn knob for managing most of the console’s operations, resulting in a user experience reminiscent of a smartphone.



Fast, flexible, full-spec setup

Transporting, unloading, and setting up a sound reinforcement system at a venue can be one of the most laborious tasks a sound engineer undertakes. Not so with the DM3 Series which requires less space and time for configuration and physical setup thanks to flexible patching along with Quick Pro Presets, Editor and StageMix software, and Dante compatibility (DM3 model only), minimizing system setup and configuration time considerably. Combining all this with 6 mix + 2 matrix + 2 effects processors, the DM3 Series are powerful, compact, sturdy consoles that you can take anywhere.

Lightweight construction for supreme portability

Thanks to precise structural design and material selection, the DM3 Series combines a light weight of only 6.5 kg with a robust housing that can stand up to the rigors of touring.



Effects to enhance the creativity of sound engineers

The DM3 Series comes equipped with two high-quality multi-effects processors featuring eighteen types of high-grade effects including the REV HD and REV R3—the first of its kind in Yamaha mixers—offer sound engineers the freedom to craft a sound that accurately reflects their own sonic sensibilities.



A wealth of applications to support any venue

A wide range of applications help users respond as the situation demands, including DM3 Editor to complete settings in advance well before the performance, DM3 StageMix to remotely control the DM3 Series from on-stage, and MonitorMix, which allows each performer to adjust their own monitor.



The most compact Dante-compatible console

Yamaha's most compact Dante-compatible mixer, the DM3 delivers high-quality 96kHz sound using 16 analog inputs and eight outputs with low latency, and matches perfectly with the Tio1608-D I/O Rack for simpler, faster system setup.

*There are two models in the DM3 series, the Dante-equipped DM3 and the DM3 Standard, which does not feature Dante.



System Example

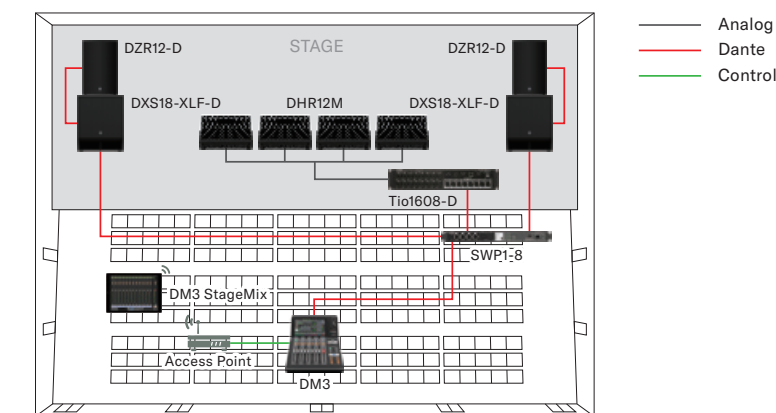



STREAMING

Professional-quality live streaming has never been easier

Live streaming brings with it unique technical demands that are often a challenge to accommodate without additional outboard gear and the space it requires. The DM3 Series comes equipped with a USB connection that lets you go live in an instant, paired with a condensed suite of features such as matrices, flexible patching, and factory presets that are aimed specifically at making live streaming seamless and trouble-free. The compact design also makes the DM3 Series ideally suited to multi-console configurations where it would take on a live-streaming role while the other console is used for on-site mixing.

A comprehensive suite of streaming features

The DM3 Series condenses features needed for streaming inside a compact housing. Units are equipped with abundant analog I/O and USB terminals, making it possible to input audio to the DM3 Series and transmit the mixed audio directly to a computer with streaming software launched. With stereo and matrices, audio routing provides a high degree of freedom and allows mixing of audio for on-site and streaming use separately.

In addition, the Dante-equipped DM3* is ideal for standalone operation as well as for use as part of a larger streaming system featuring multiple consoles. For example, using two DM3 units allows the engineer to input the audio transmitted by Dante for on-site and streaming, or use two different mixes for these. The compact housing makes it the ideal console where space is limited, or for use in system expansion.

*The DM3 Standard is an analog model, while the DM3 is a Dante-compatible model.



DM3

Flexible patch settings

The DM3 Series inputs and outputs allow patches to be freely changed with ease. These consoles can handle minor modifications to the system flexibly to suit any location, which is extremely useful in situations where teams are divided by role.

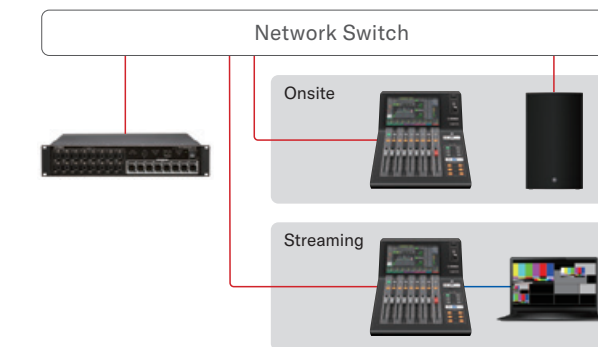
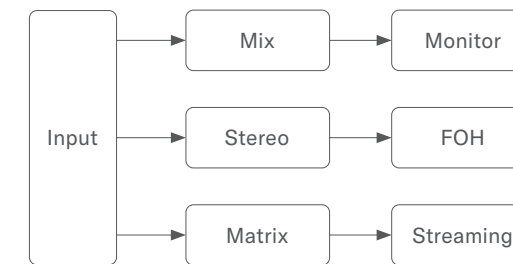

System Example

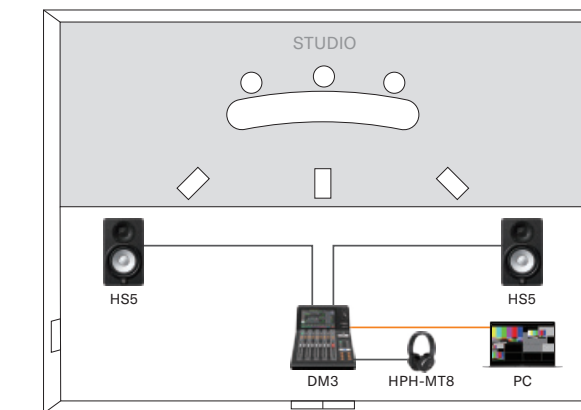

— Analog
— USB



RECORDING

Comprehensive recording and editing functions in a compact body

A supremely portable, full-spec music production tool, the DM3 Series covers all the bases for your live recording and home editing needs. The DAW Remote function allows you to use a range of devices to control your mix and recording from anywhere in a live venue or recording environment, then take the results home for editing at your leisure. The recorded performances can be stored directly on a USB stick, on a PC connected via USB to HOST, or on a separate Dante-compatible device (DM3 only), and edited with the bundled Cubase AI software or the DAW suite of your choice.

DAW Remote streamlines music production

DM3 Console team well with a digital audio workstation (DAW). DAW operations such as volume adjustment, play, and stop can be performed using the console's faders and buttons as physical controllers for smooth operation while arranging. The DM3 supports a variety of DAW software suites, and comes bundled with Cubase AI—a stripped-down but powerful music production software platform. Switching to DAW Remote Mode is a simple one-step operation that can be performed by pressing USER DEFINED KEYS 1 and 2 together.



Cubase AI bundled software

DM3 Series are bundled with downloadable Cubase AI software from Steinberg. As one of the most advanced, comprehensive DAW suites available, Cubase has led the charge, providing users with a powerful and flexible platform for music production. Cubase AI* offers these same core technologies and interface that have won Cubase worldwide acclaim.



Accurate Control of Monitor Levels

DM3 Series Consoles allow monitor levels to be controlled with faders. Access is simple and easy, for smoother, more accurate checking of mix balances. You can also use the customer fader function to assign monitor level control for smoother, more accurate mixes, or use User Defined Keys to adjust the volume separately by switching the source.



Multiple ways to record

Both DM3 models support multitrack recording via USB to Host, while simple 2-track recording is possible using a USB memory stick and the USB connector on the front of both consoles. The Dante-capable DM3 Console also adds multitrack recording capability using the Dante Virtual Soundcard. Put simply, the DM3 Series offers a range of recording options that give users the flexibility to meet the demands of a variety of environments and applications.

*Dante Virtual Soundcard is not included.



System Example

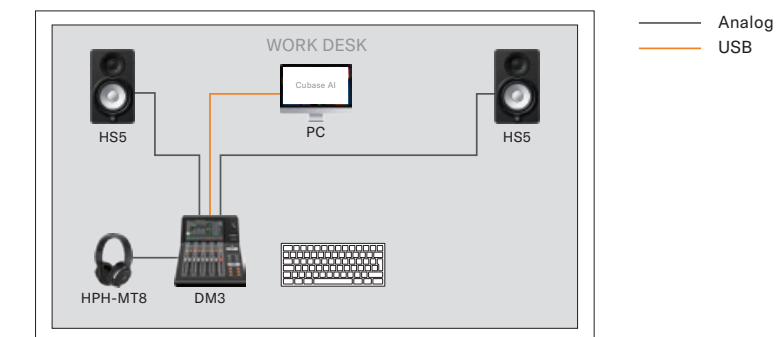



INSTALLED SOUND

Your space, your settings, your language

With each different work environment comes a new range of challenges that place different demands on a console and on users themselves. The design of DM3 Series Consoles was created with this in mind, with a customizable interface that can be tailored to match user requirements and experience levels. For example, channel names can be displayed in different languages, and operations can be restricted by user account, while ProVisionaire Touch and Control offers the user has a control panel that can be optimized for a variety of applications.

Providing optimal settings for the user

The DM3 Series is designed to be operated by a wide range of people, from professional engineers to those who rarely use a console, and its appearance varies from user to user. For example, logging in as Guest simplifies use by limiting the operations available.

DM3 Series Consoles are equipped with a wealth of user support and time-saving features, such as the GainFinder™ feature that provides visual support for gain settings, and 1-knob COMP™ & 1-knob EQ™, which allows multiple parameters to be controlled with a single knob. In addition, channel names are Unicode-capable and can be input in various languages, making the DM3 Series highly effective and user-friendly mixers that are especially useful for applications when the console is used by multiple users of varying languages and skill levels.*

The optional RK-DM3 allows for rack mounting and flexible installation.

*Input for channel names in languages other than English can be performed using DM3 Editor or DM3 StageMix.

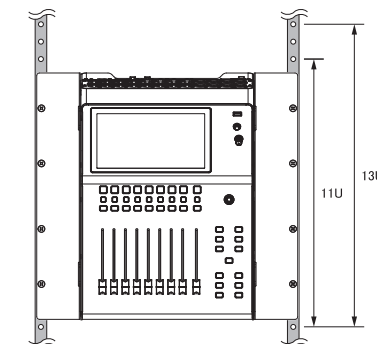

System Example

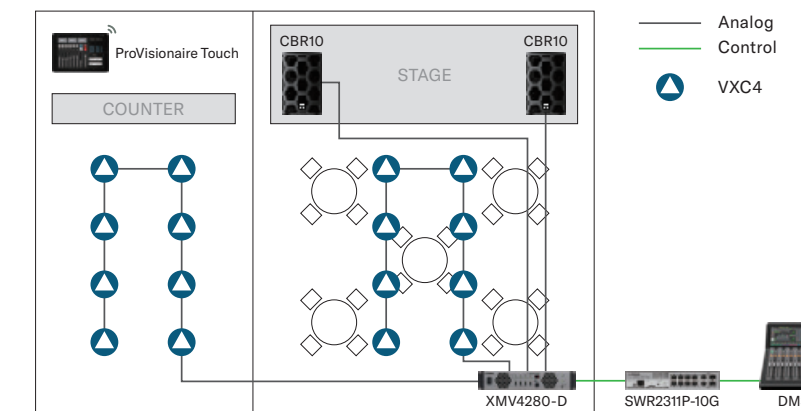

Abundant options for remote control

The DM3 Series is compatible with a variety of external controls. In addition to Yamaha's custom control panel ProVisionaire Series, these consoles support general-use communication protocols OSC (via Ethernet) and MIDI (via USB), offering flexibility for remote control.



ProVisionaire Control



ProVisionaire Touch

General Specifications

Mixing Capacity	Input channels	16 Mono, 1 Stereo, 2 FX Return
	Buses	1 Stereo, 6 Mix, 2 FX, 2 Matrix (Input to Matrix supported)
Local Connectors	Analog In	16 Mic/Line (12 XLR + 4 XLR/TRS Phones Combo)
	Analog Out	8 (XLR)
	Dante I/O (DM3 only)	2 (etherCON : Primary/Secondary, 16 In/Out)
	Ethernet	1 (RJ-45)
	USB to Host	1 (USB Type-B)
	USB to Device	1 (USB Type-A)
	Phones	1 (TRS Phones)
User Interface	DC IN	1 (XLR 4pin)
		9-inch multi-touch screen 9 x 100mm Motorized fader (8 channels + 1 master) 1 x Rotary Encoder (Touch and Turn)
Recording & Playback	PC (via USB to Host) (USB 2.0)	Recording 18 track Playback 18 track
	USB storage device	Recording 2 track Playback 2 track
Sampling rate		96 kHz/48 kHz
Power Requirements		DC24 V/2.5 A, PA-L500 (100 V-240 V, 50 Hz/60 Hz)
Power Consumption		43 W
Dimensions (W x H x D)		320 mm x 455 mm x 140 mm
Weight		6.5 kg
Temperature Range		Operating Temperature Range: 0 to 40°C Storage Temperature Range: -20 to 60°C
Accessories		Owner's Manual, Power Adapter (PA-L500, including power cord), CUBASE AI Download Information
Options		Rack mount kit RK-DM3, I/O RACK Tio1608-D

*1 Total Harmonic Distortion is measured with a -18 dB/octave filter@80 kHz.

*2 Hum & Noise are measured with an A-Weight filter.

*3 Crosstalk is measured with a -30 dB/octave filter@22 kHz.



DM3/DM3 Standard

Rear



DM3

Dimensions

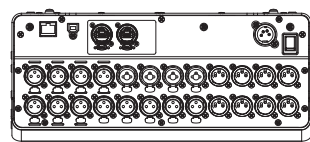

DM3

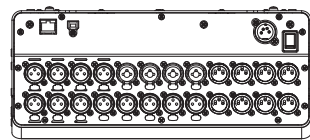

DM3 Standard

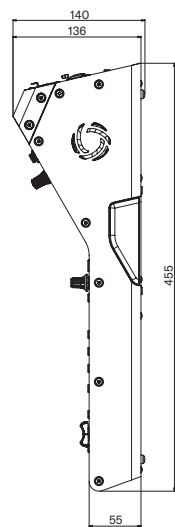
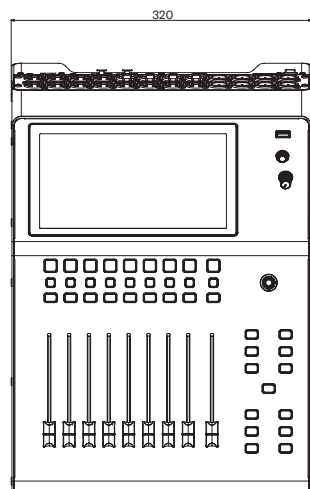

mm



DM3 Standard

Related Software



DM3 Editor

DM3 Editor is a stand-alone application for Windows or Mac that works for both online operation and offline configuration and editing.



DM3 StageMix

DM3 StageMix is an iPad application that enables remote control of the DM3 Series through a simple and intuitive graphical interface. The engineer can control the mix parameters from the performer's position on the stage.



MonitorMix

The MonitorMix application for iOS and Android devices puts control of each performer's monitor mix into the palm of their own hand.



ProVisionaire Control/Touch

The ProVisionaire Series is software that allows you to create control panels tailored to your installation and operation methods to remotely control and monitor your equipment. ProVisionaire Control for Windows and ProVisionaire Touch for iPads offer control of a wide range of devices, including the DM3 Series.

Options

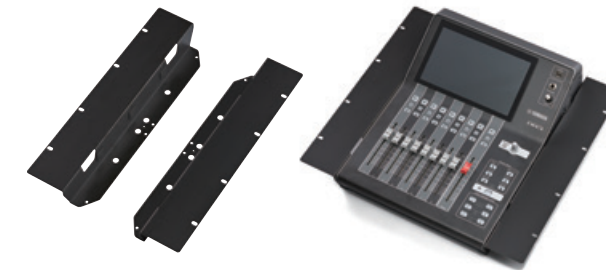

RK-DM3

The DM3 Series can be rack mounted using RK-DM3, which fits in a size 13U mounting.



Tio1608-D

The Tio1608-D is a Dante-equipped I/O rack with 16 microphone/ line inputs and 8 line outputs. A stage box system can be built with DM3 that transmits high sound quality at 48 kHz with low latency. In addition to being able to control the DM3 to the Tio1608-D's internal preamp, the Auto Setup feature enables setup with minimal effort.